

## IMPROVED MIXING USING MULTIPLE SWIRLING JETS

A. Khelil<sup>1</sup>, M. Braikia<sup>1</sup>, H. Naji<sup>2\*</sup> and L. Loukarfi<sup>1</sup>.

<sup>1</sup> Université H.B., B.P. 151, 2000 Chlef, Algérie.

<sup>2</sup> Université Lille 1 - Sciences et Technologies, Polytech'Lille, LML – UMR 8107 CNRS, Boulevard Paul Langevin, 59655 Villeneuve d'Ascq, France.

\* Corresponding author. Tel :+33(0)328767359; Fax: +33(0)328767301  
E-mail address: [hassan.naji@polytech-lille.fr](mailto:hassan.naji@polytech-lille.fr) (H.Naji)

### ABSTRACT

The influence of several parameters such as the inclined vanes of diffuser and the sense of rotation of the single or multiple swirling jets, their number and their arrangement on the flow resulting thermally was experimentally investigated. Experiences concerning the fusion of several jets show that gas mixtures are clearly more homogenized under swirling influence. The results of this study show that the gap between the jets and their sense of rotation relative to the central jet, affects the quality of homogenization jets blown. Compared with the single jet, under uniform velocity and temperature, the multi-swirling jet with an angle of greater openness ensures a stable temperature distribution.

*Keywords:* Multiple free jets; swirling flow; homogenisation; vanes swirler.

### 1 INTRODUCTION

Swirling jets are usually used for practical heat transfer devices. These, they present an interesting flow pattern for practical and theoretical standpoints. Practically they appear in aircraft combustors and a residential/commercial burner where swirl helps to improve mixing and stabilizes the flame. They are also widely used in industrial burners of power station furnaces or gas turbine combustors to provide stable, high intensity, short flames with wide radial development resulting from good fluid mixing [1, 2]. There are still many questions concerning the understanding of the effect of swirl on heat transfer and behaviour of the induced flow [3]. The induced air entrainment by the rapid decrease of the average velocity implies a significant transfer of radial momentum. In general, experimental results show that the swirl increases the spread of the jet. This finding is further accentuated when the swirl number increases [4-7].

Understanding the effects of swirl, particularly on the entrainment rate of air and on rate of stratification of multiple jets which affects the

efficiency of the air conditioning process is of great importance. [8-9].

Multiple swirling jets have been used for enhancing heat transfer in rapid heating, ventilation systems and cooling systems. When high heat transfer coefficients are needed over a wide area,

Consequently the fusion of many swirling jets becomes interesting to study. The multiple swirling free jet studies show that the swirling jets will develop more rapidly than the jets without swirl. Note that the number of jets causes a decrease in velocities, and the distance between blowing orifices also diminishes velocities while delaying jets fusion. Far from the orifice and for large numbers of swirl, velocity profiles of multiple jets tend increasingly to those of the single jet. The interaction between the jets allows distribution of velocities in the mixing zone. This region is the seat of normal stresses and maximum shear. The profiles obtained near the swirler have irregularities due to the geometry and conditions of blowing. The decrease in axial temperature for the multijet seems to be exponential. It is less marked when the resulting jet encounters an obstacle. [10-15].

Optimization of these parameters would then influence the quality of the stratification made in

the atmosphere treated suggesting the applicability of the interaction of swirl jets in the heating and space cooling of high-rise. According to the literature available there is no advanced research being done, on the multiple swirling jets applied to climatic comfort. The majority of the existing literature deals with multiple swirling jets in various geometric or dynamic conditions, applied to the improvement of combustion.

The aim of this study is to examine the influence of various parameters such as the sense of rotation of the single or multiple swirling jets, their number and arrangements on the flow resulting thermally. Optimization of these parameters would then influence the quality of the stratification made in the atmosphere treated allowing choosing the optimal configuration of interest to industrial.

## 2 EXPERIMENTAL SETUP

The experimental facility consists of a chassis on which is fixed a square Plexiglas plate. On the latter, 7 devices blowing hot air (hair dryer type TEFAL-1500) are fixed and directed downwards, and the lower part of these devices is used to fix different types of diffusers with inclined vanes, depending on the studied configuration. Temperatures and velocity of the flow is measured by a thermoanemometer (type velocicalc+ model [16]) which is a high-precision multifunctional instrument. The data can be viewed on screen, printed or downloaded to a spreadsheet program allowing us to easily transfer data to a computer for statistical treatment. The accuracy is of order  $\pm 0.015(m/s)$  for velocity and  $\pm 0.3(^{\circ}C)$  for temperature from thermal sensor [16]. Note that the thermal sensor is supported by rods that are easily guided vertically and horizontally to sweep the maximum space in the axial and radial directions. The swirling free jet used here is different from the conventional jet because of the existence a tangential component velocity. To obtain this kind of flow, one can use rotary mechanical systems or a static system; it is the latter that we have chosen here. It is composed of inclined vanes (see Fig. 1) which is put in the generating tube jet. The application of a tangential velocity component to the flow ( $W$ ) provides a rotation to flow fluid, which can be by a non-dimensional swirl number ( $S$ ). This number is defined as the ratio of the axial flux of tangential momentum to the product of the axial momentum flux and a characteristic radius [17].

$$S = \frac{\int_{R_n}^{R_h} UW r^2 dr}{\int_{R_n}^{R_h} R_n U^2 r dr} \quad 1$$

where  $R_n$  and  $R_h$  are the radius of the centre body and the inlet duct, respectively and if the axial and azimuthally velocities are assumed to be uniform and the vane are very thin. In this study, the flow rate was adjusted at Reynolds numbers ( $Re_0$ ) ranging from 10000 to 30000. Study has been done under uniform heat flux condition for each diffuser ( $S < 1.3$ ,  $Q_m \leq 54$  g/s,  $x/D$  and  $r/D = 1$  to 10) and air was used as working fluid.

Where:

$S$  is the swirl number .

$Q_m$  is masse flow rates (g/s).

$D$  is inner diameter of one diffuser (m).

$X$  is axial coordinate of the air flow (m).

$R$  is radial coordinate of air flow (m).

We define a dimensionless temperature quantity  $Tr$

$$Tr = \frac{(T - T_a)}{(T_{max} - T_a)} \quad (2)$$

Where:

$T$  is jet temperature ( $^{\circ}C$ ).

$T_a$  is ambient temperature ( $^{\circ}C$ ).

$T_{max}$  is maximum temperature ( $^{\circ}C$ ).

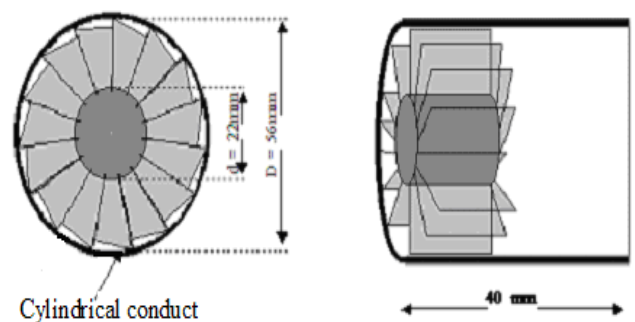

Figure 1. Schematic of generator device swirling.

## 3. RESULTS AND DISCUSSION

### 3.2 Linear configuration of three swirling jets

Fig. 2 shows the device of triple swirling jets with two different temperature blowing (A2 and B2) and the space between jets axes is equal to  $2D$ . The radial temperatures profiles associated with configurations A2 and B2 at location  $x/D = 8$  is presented in Fig. 3. One can stress that the

temperature varies slowly in cases A2 and B2. Also, the triple swirling jets with configuration A2 allows a more thermal homogenization with a more important spreading of the resulting jet (see Fig. 3, legend A2).

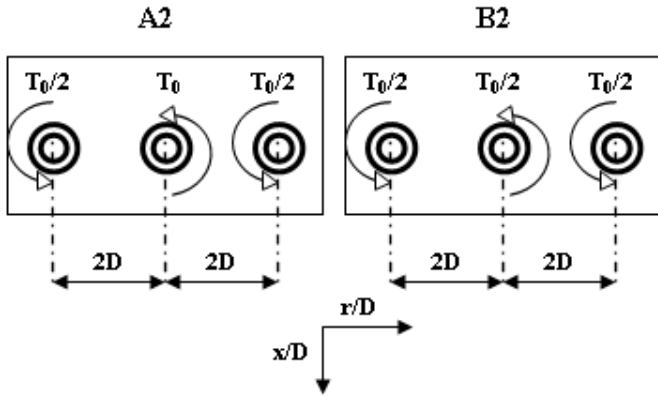

Figure 2. Configurations with swirling triple jet.

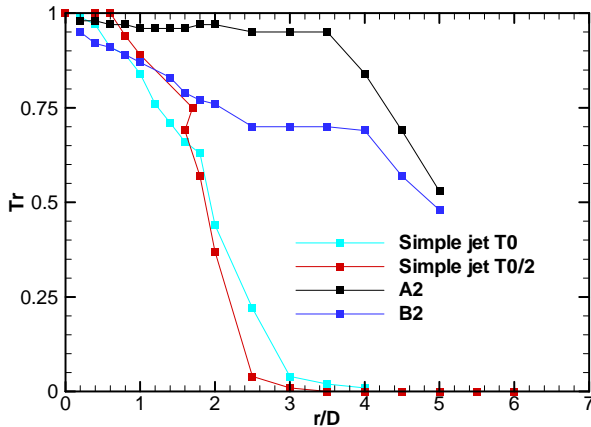

Figure 3. Radial temperatures profiles for configurations A2 and B2 at the station  $x/D = 8$ .

### 3.1 Plane configuration with four jets arranged in triangle

In the Fig. 4, we give the equilateral triangular arrangement of the configuration with four jets including a central jet. The space between jets axes is equal to  $2D$  (see Fig.4). Fig. 5 shows the axial evolution of temperature for cases of the single central jet, the three jets and the four jets, respectively. For the case of the central jet, we note that the temperature decreases rapidly. In the case where only the peripheral jets are active, the temperature begins to increase because of the mixture and then decreases. However, where all four jets are active, the temperature decreases less rapidly compared to the first case. Indeed, the central jet modifies the adjacent behaviour of peripheral jets and improves the homogenization of

flow and the temperature decreases monotonically. This may explain the monotonic decrease of the temperature

The development of the radial temperature at position  $x/D=8$  is shown in Fig.6 for the same cases as above. Again, we note that the temperature decreases in the radial direction. This trend is more pronounced in the case of the single central jet. As can be seen, evolution of the radial temperature remains almost constant because of the effect of central jet.

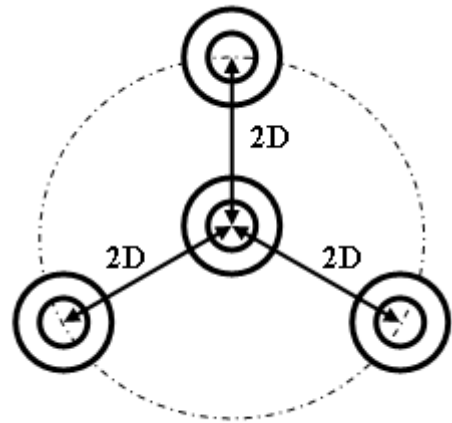

Figure 4. Quadruple swirling jet configuration.

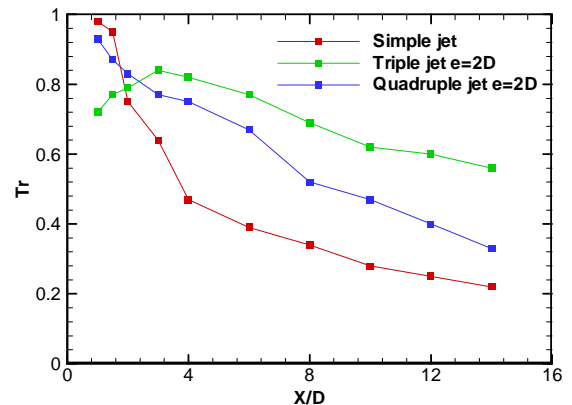

Figure 5. Axial temperature profiles for 3 and 4 swirling jets in triangle arrangement.

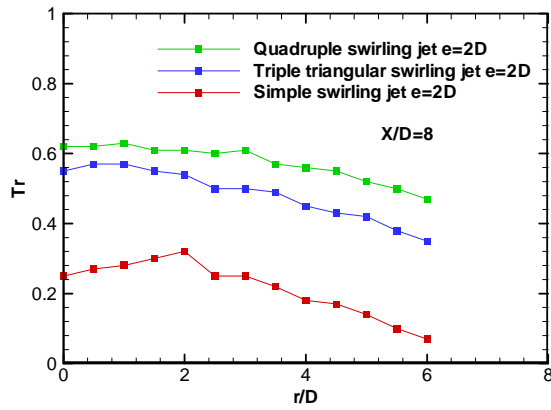

Figure 6. Radial temperatures profiles at the station  $(x/D) = 8$  for 3 and 4 swirling jets in triangle arrangement.

### 3.2 Plane configuration with five jets

Fig. 7 shows schematically the studied configuration, which consists of 4 jets surrounding the central jet and the space between jets axes is equal to  $2D$ . The peripheral jets are inclined by  $\phi=0^\circ, 30^\circ, 45^\circ$  and  $60^\circ$ , respectively. The effect of the inclination of the peripheral jet is investigated at the location  $x/D=8$  (see Fig. 8). Analysing this figure, one can note that the decrease of the temperature is pronounced when the inclination is large, while allowing a stable distribution. Moreover, the gap between blowing orifices do not exceed a limited value. Otherwise the interaction between the jets will not have the desired effect for a good homogenization.

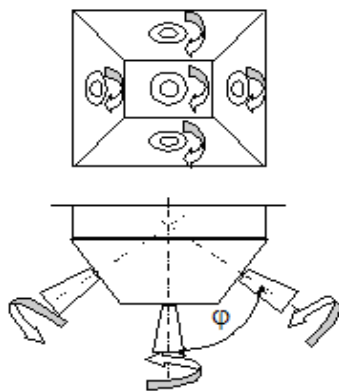

Figure 7. Schematic view of the configuration with five swirling jets.

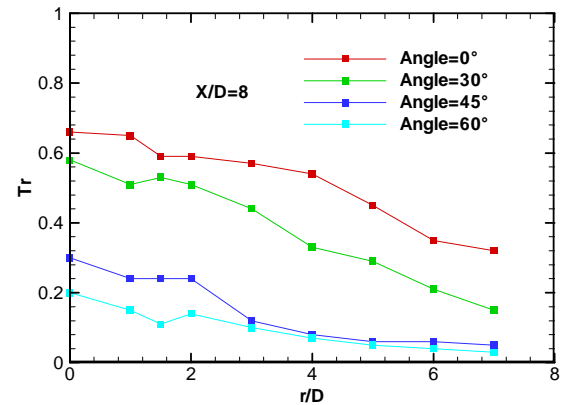

Figure 8. Radial temperature profiles for different inclinations of the 4 peripheral swirling jets, the fifth jet being central.

### 3.5 Plane configuration with 7 jets

The configuration consists of 7 swirling jets including a central jet and the space between jets axes is equal to  $2D$  (see Fig; 9). Fig. 10 shows the radial evolution of the dimensionless temperature for different positions  $x/D$ . We note that all curves decrease from the origin ( $x/D=0.0$ ) except for the curve at  $x/D=1$ . Away from the orifice, the radial profiles decrease slowly becoming almost constant at  $x/D=10$ . At this station, the thermal homogenization is almost complete (see Fig. 10).

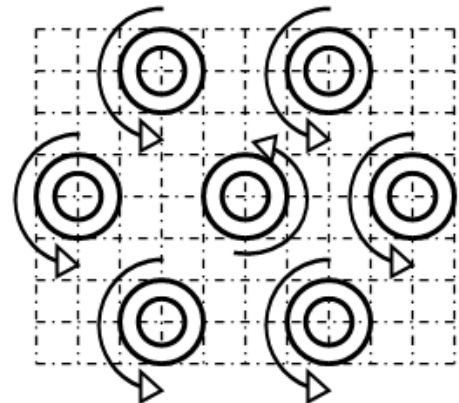

Figure 8. Seven swirling jets arrangement.

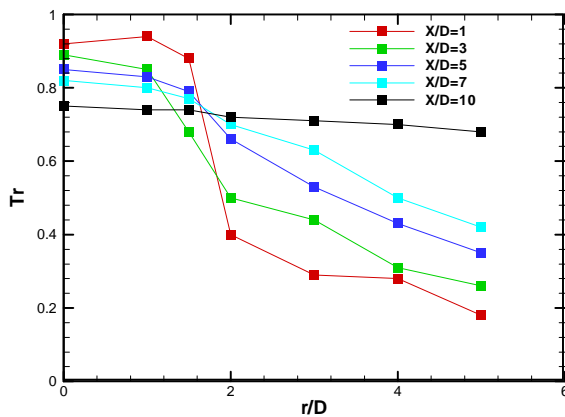

Figure 10. Radial profiles of the temperature for the configuration with 7 swirling jets.

#### 4 Conclusion

The multiple swirling jets associated with the choice of the position of blowing air can significantly improve the quality of thermal homogenization of the treated space. The interaction between swirling jets induces the redistribution of temperature in the mixing zone as for velocities [3], while allowing the spreading of the resulting jet. Also, in all studied configurations, the central jet has a significant role in the enhancement of the homogenization. The optimization of parameters such as the diffuser's geometry, the inclination of the initial velocity, the spacing between jets, the number of blowing jets, the inclination of lateral jets from the central axis of the resulting jet and the relative rate between the central jet and peripheral jets contributes to improve the quality of thermal air homogenization in the conditioned space.

#### REFERENCES

[1] Y. Huang, V. Yang, *Progr. Energ. Combust. Sci.* 35,293-364, 2009.

[2] A. Khelil, H. Naji, L. Loukarfi, G. Mompean, *Fuel* 88 , 374–381, 2009.

[3] L. Loukarfi, *Thèse de Doctorat d'Etat*, UHBC Algérie, 1998.

[4] P. Florent, L. Loukarfi, Utilisation de mélange de jets hélicoïdaux pour le chauffage de grands bâtiments, SFT., *Congrès Français de Thermique*, Valenciennes (France), 1996.

[5] L. Loukarfi, P. Florent, A. Bettahar, B. El Andaloussi, Quelques configurations de jets triples tourbillonnaires en

vue de l'homogénéisation thermique d'une ambiance, *13<sup>ème</sup> Congrès Français de Mécanique*, Poitiers ,1997.

[6] L. Loukarfi, P. Florent, A. Bettahar, *Entropie* 216,37-45,1999 .

[7] S. Lalot, X. Potier, L. Loukarfi, P. Florent, *Trans.C.S.M.E.* 25 , 2001.

[8] B. Janus, A. Dreizler, J. Janicka, *Pro. Combust. Inst.* 31 , 3091–3098, 2007.

[9] E.P. Volchkov, V.P. Lebedev, V.I. Terekhov, N.E. Shishkin, *Int. J. Heat and Mass Trans.* 43 375-386, 2000.

[10] M.V. Heitor, A.L. N.Moreira, *Exp. Fluids*, 13 179-189, 1992.

[11] S. Polat, W.J.M. Douglas, *AIChE J.* 36,1370-1378,1990 .

[12] C.H.I. Manohar, *Int. J. Num. Meth. Fluids*, 44 431–446, 2004.

[13] S .Al-Shyyab, H. Tlilan, A. Ababneh, , *Energ. Convers. Management* 50 (2009) 1625–1633.

[14] D.F. G.Durao, M. Heitor, A.L.N. Moreira, Part I, *J of Fluid Engineering Transactions of the ASME* 113, 668-374, 1991.

[15] M. Teamah, S. Farahat, *Alexandria Engineering J.* 45 ,1-13, 2006.

[16] Velocicalc Plus Air velocity Meter, Operation and Service Manual 1980321, Revision H, June 2006.

[17] A.K. Gupta, D.G. Lilley, N. Syred, *Swirl flows*, London: Abacus Press, 1984.